

DVQ Series Single Vane Pumps

Maximum pressure 210 bar

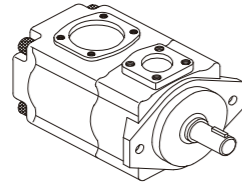

DVQ20
Weight : Flange Type 12.5 Kg
Foot Type 15 Kg

DVQ25
Weight : Flange Type 18 Kg
Foot Type 23 Kg

Model number	-26 Displacement c.c/rev	-F Mounting Type	-R Rotation	A Discharge Position	A Suction Position	01 Shaft Type
DVQ20	6,8,11,14 17,19,23 26,32,34, 38,44	F: Flange Type	View from Shaft End R: Clockwise	A: Upward (Normal) B: Downward	A: Upward (Normal) B: Downward	01: Normal
DVQ25	18,22,26 32,38,43 47,52,60 65,75	L: Foot Type	L: Anti- Clockwise	R: On Right Hand L: On Left Hand	R: On Right Hand L: On Left Hand	

Model	Deliver Flow (ℓ /min) at no-load pressure				Running Speed (rpm)		Max Pressure (Kg/cm ²)		
	Running Speed (rpm)				Max	Min	Cont.	Peak.	
	1000	1200	1500	1800					
DVQ20	06	6.2	7.4	9.3	11.2	1800	800	210	260
	08	8.1	9.7	12.1	14.6	1800	800	210	260
	11	11.2	13.4	13.4	20.1	1800	800	210	260
	14	14.3	17.1	21.5	25.7	1800	800	210	260
	17	17.1	20.5	25.6	30.7	1800	800	210	260
	19	19.2	23.0	28.8	34.5	1800	800	210	260
	23	23.3	27.9	34.9	41.9	1800	800	210	260
	26	26.1	31.3	39.1	46.9	1800	800	210	260
	32	32.1	38.3	47.6	—	1500	800	175	240
	34	34.1	40.8	50.4	—	1500	800	175	240
DVQ25	38	38.1	45.9	—	—	1200	800	175	240
	44	44.1	52.9	—	—	1200	800	175	210
	18	18.1	21.7	27.2	32.6	1800	800	210	260
	22	22.1	26.5	33.3	39.8	1800	800	210	260
	26	26.2	31.4	39.3	47.1	1800	800	210	260
	32	32.1	38.5	48.1	57.7	1800	800	210	260
	38	38.2	45.8	57.3	68.7	1800	800	210	260
	43	43.2	51.8	64.8	77.7	1800	800	210	260
	47	47.1	56.5	70.0	85.0	1800	800	210	260
	52	52.3	62.7	78.4	94.1	1800	800	210	260
	60	60.2	72.7	90.3	108.3	1800	800	210	260
	65	65.3	78.3	97.9	117.5	1800	800	210	230
	75	75.0	90.0	112.5	—	1500	800	210	230

DVQ Series Single Vane Pumps

Maximum pressure 210 bar

DVQ20 (Flange-Mount Type)

Max. Pressure: 260 Kg/cm² (Peak)
Max. Speed: 1800 rpm

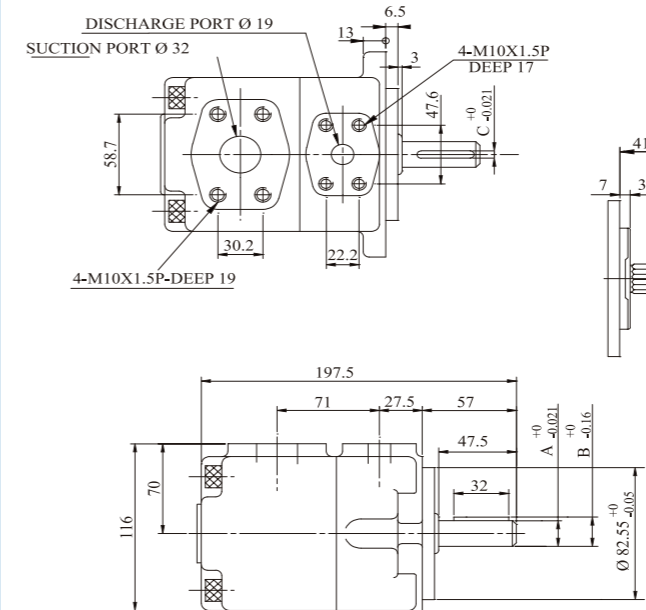

DVQ20 (Base-Mount Type)

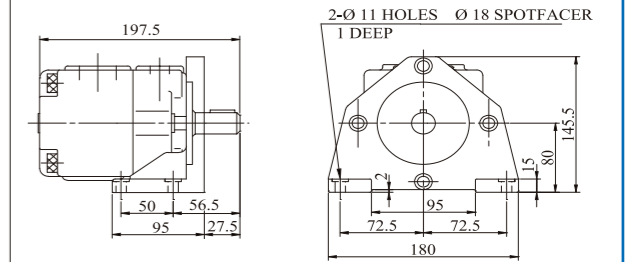

For other dimensions, please refer to the flange-mount type.

NO.04-Shaft

13-Teeth Spline
7/8" (22.225)DIA
30° pressure angle
Flat root side fit

	A	B	C
NO.01-Shaft	Ø 19.05	21.24	4.76
NO.02-Shaft	Ø 22.23	24.5	4.76
NO.03-Shaft	Ø 22.23	25.01	6.35
NO.04-Shaft	Spline shaft		

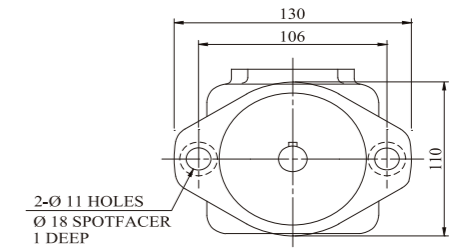

DVQ25 (Flange-Mount Type)

Max. Pressure: 260 Kg/cm² (Peak)
Max. Speed: 1800 rpm

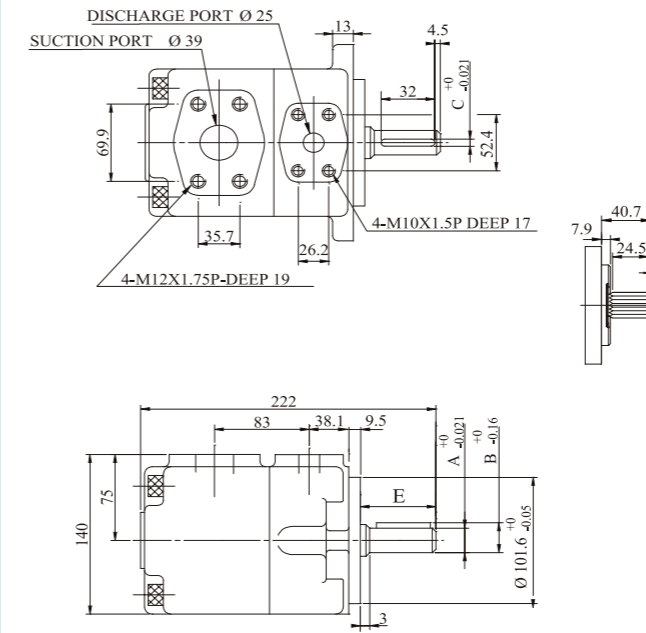

DVQ25 (Base-Mount Type)

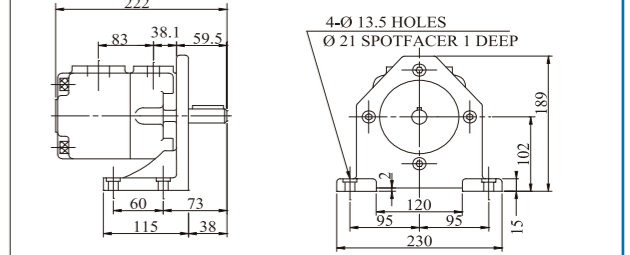

For other dimensions, please refer to the flange-mount type.

NO.04-Shaft

16/32 d.p.
-13 teeth
30° pressure angle
Flat root side fit.

	A	B	C	E
NO.01-Shaft	Ø 22.23	24.5	6.35	50.5
NO.02-Shaft	Ø 25.4	28.18	6.35	50.5
NO.03-Shaft	Ø 30.0	33.0	7.0	59
NO.04-Shaft	Spline shaft			
NO.W-Shaft	Ø 28.0	30.8	6.35	50.5

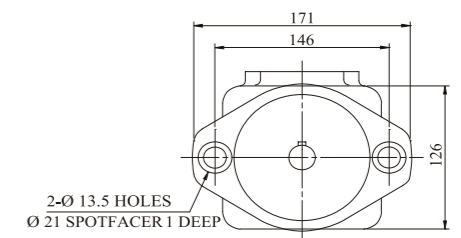

VQ Series Single Vane Pumps

Maximum pressure 210 bar

VQ15
VQ20 SVQ25
VQ25 SVQ35
VQ35 SVQ45
VQ45 DVQ45

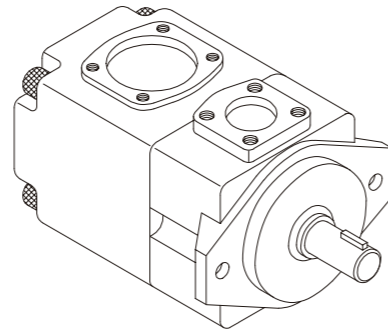

ORDERING CODE

VQ15	-17	F	R	A	A	-01
Model number	Displacement c.c/rev	Mounting Type	Rotation	Discharge Position	Suction Position	Shaft Type
VQ15	6,8,11,14,17,19,23,26,31,38	F: Flange Type	View from Shaft End R: Clockwise	A: Upward (Normal)	A: Upward (Normal)	-01
VQ20	6,8,11,14,17,19,23,26,31,38			B: Downward	B: Downward	-02
VQ25 SVQ25	18,22,26,32,38,43,47,52,60,65,75	L: Foot Type	L: Anti-Clockwise	R: On Right Hand	R: On Right Hand	-03
VQ35 SVQ35	60,66,76,82,88,94,108,116,125			L: On Left Hand	L: On Left Hand	
VQ45 SVQ45 DVQ45	136,156,189,200,216,237					

SINGLE PUMP WEIGHT LIST (Kg)

	VQ15	VQ20	VQ25	SVQ25	VQ35	SVQ35	VQ45	DVQ45	SVQ45
Flange Type	10.3	12.3	16.7	23	36	33	52	61	66.5
Foot Type	12.7	17	21.4	31	44	41	60	92	98
Outlet & Inlet Flange	0.9	0.9	1.6	1.6	2.0	2.0	3.2	3.2	3.2

VQ Series Single Vane Pumps

Maximum pressure 210 bar

VQ Series Operating Pressure Specifications

Model	Geomefric displ. (c.c/rev)	Using antiwer oil or Phosphate ester fluid		Using water glycol fluid		Using water-in-oil emulsions		Min Speed (rpm)
		Max Pressure (Kgf/cm ²)	Max Speed (rpm)	Max Pressure (Kgf/cm ²)	Max Speed (rpm)	Max Pressure (Kgf/cm ²)	Max Speed (rpm)	
VQ15	06	210	1800	160	1200	140	1200	800
	08							
	11							
	14							
	17							
	19							
	23							
	26							
	31							
VQ20	38	175	1500	160	1200	140	1200	800
	06							
	08							
	11							
	14							
	17							
	19							
	23							
	26							
VQ25 SVQ25	31	210	1800	160	1200	140	1200	800
	38							
	18							
	22							
	26							
	32							
	38							
	43							
	47							
VQ35 SVQ35	52	175	1800	160	1200	140	1200	600
	60							
	65							
	75							
	60							
	66							
	7							
	82							
	88							
VQ45 SVQ45 DVQ45	94	175	1800	140	1200	140	1200	600
	108							
	116							
	125							
	136							
	156							
	189							
	200							
	216							
237								

VQ Series Flow and Pressure Characteristics Table

Model	Delivery Flow (ℓ /min) at no-load pressure				Running Speed (rpm)		Max Pressure (Kgf/cm ²)		
	Running Speed (rpm)				Max	Min	Cont.	Peak.	
	1000	1200	1500	1800					
VQ15	06	6.2	7.4	9.3	11.2	1800	800	210	240
	08	8.1	9.7	12.1	14.6	1800	800	210	240
	11	11.2	13.4	16.8	20.1	1800	800	210	240
	14	14.3	17.1	21.5	25.7	1800	800	210	240
	17	17.1	20.5	25.6	30.7	1800	800	210	240
	19	19.2	23.0	28.8	34.5	1800	800	210	240
	23	23.3	27.9	34.9	41.9	1800	800	210	240
	26	26.1	31.3	39.1	46.9	1800	800	210	240
31	31.1	37.3	46.6	—	1500	800	175	240	
38	38.1	45.6	—	—	1200	800	175	230	
VQ20	06	6.2	7.4	9.3	11.2	1800	800	210	230
	08	8.1	9.7	12.1	14.6	1800	800	210	230
	11	11.2	13.4	16.8	20.1	1800	800	210	230
	14	14.3	17.1	21.5	25.7	1800	800	210	230
	17	17.1	20.5	25.6	30.7	1800	800	210	230
	19	19.2	23.0	28.8	34.5	1800	800	210	230
	23	23.3	27.9	34.9	41.9	1800	800	210	230
	26	26.1	31.3	39.1	46.9	1800	800	210	230
31	31.1	37.3	46.6	—	1500	800	175	230	
38	38.1	45.6	—	—	1200	800	175	230	
VQ25 SVQ25	18	18.1	21.7	27.2	32.6	1800	800	210	230
	22	22.1	26.5	33.2	39.8	1800	800	210	230
	26	26.2	31.4	39.3	47.1	1800	800	210	230
	32	32.1	38.5	48.1	57.7	1800	800	210	230
	38	38.2	45.8	57.3	68.7	1800	800	210	230
	43	43.2	51.8	64.8	77.7	1800	800	210	230
	47	47.1	56.5	70.0	85.0	1800	800	210	230
	52	52.3	62.7	78.4	94.1	1800	800	210	230
60	60.2	72.7	90.3	108.3	1800	800	210	230	
65	65.3	78.3	97.9	117.5	1800	800	210	230	
75	75.0	90.0	112.5	—	1500	800	210	230	
VQ35 SVQ35	60	60.3	72.3	90.4	108.5	1800	600	175	210
	66	66.4	79.6	99.6	119.5	1800	600	175	210
	76	76.3	91.5	114.4	137.3	1800	600	175	210
	82	82.2	98.6	123.3	147.9	1800	600	175	210
	88	88.3	105.9	132.4	158.9	1800	600	175	210
	94	94.5	113.4	141.7	170.1	1800	600	175	210
	108	108.2	129.8	162.3	194.4	1800	600	175	210
	116	116.1	139.3	174.1	208.9	1800	600	175	210
125	124.6	149.5	186.9	—	1500	600	175	210	
VQ45 SVQ45 DVQ45	136	136.8	164.0	204.0	246.0	1800	600	165	175
	156	156.2	188.0	234.0	280.0	1800	600	165	175
	189	189.5	227.0	284.0	340.0	1800	600	165	175
	200	200.0	240.0	300.0	360.0	1800	600	165	175
	216	216.0	260.0	324.0	—	1500	600	165	175
237	237.0	285.0	355.0	—	1500	600	165	175	

VQ15 (Flange-Mount Type)

Max. Pressure: 240 Kgf/cm² (Peak)
Max. Speed: 1800 rpm

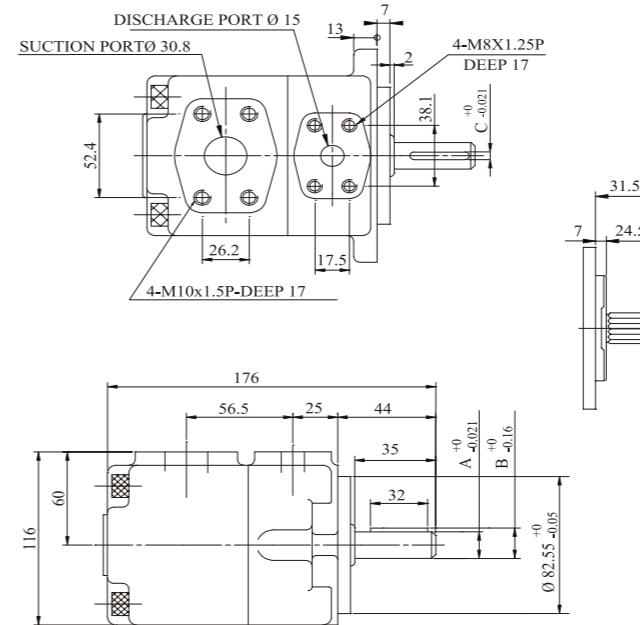

VQ15 (Base-Mount Type)

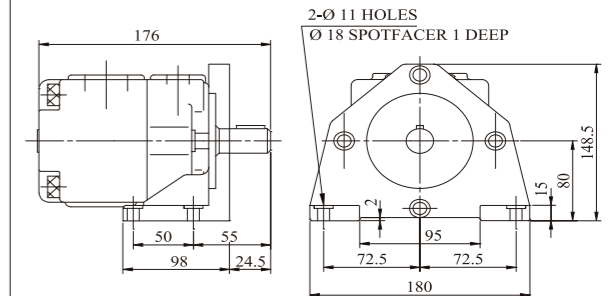

For other dimensions, please refer to the flange-mount type.

NO.03-Shaft

11-Teeth Spline
3/4" (19.05) DIA
30° pressure angle Flat root side fit

	A	B	C
NO.01-Shaft	Ø19.05	21.24	4.76
NO.03-Shaft	Spline shaft		

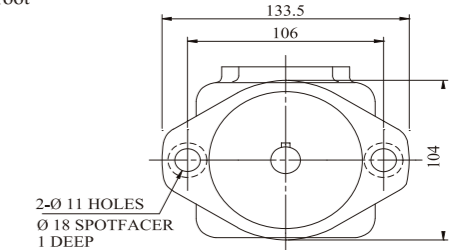

VQ20 (Flange-Mount Type)

Max. Pressure: 230 Kgf/cm² (Peak)
Max. Speed: 1800 rpm

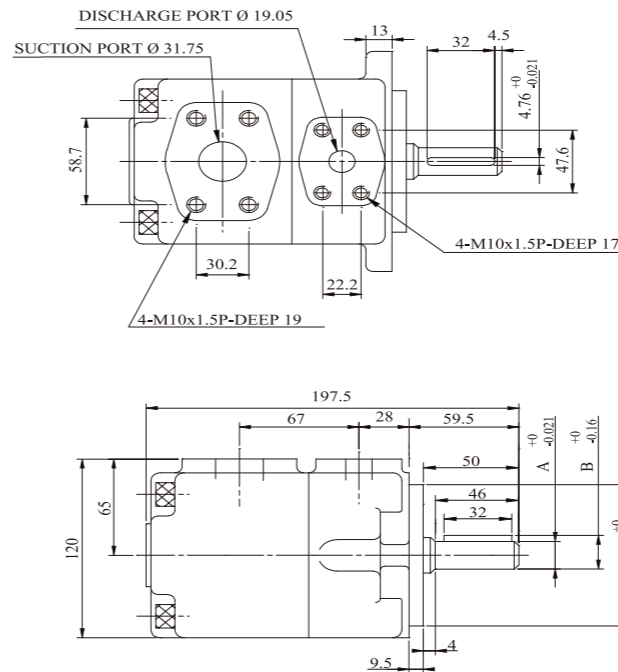

VQ20 (Base-Mount Type)

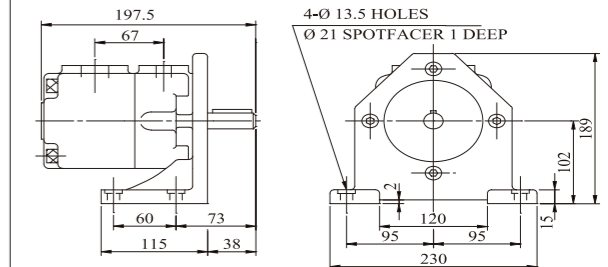

For other dimensions, please refer to the flange-mount type.

	A	B	C
NO.01-Shaft	Ø 22.23	24.5	4.76
NO.02-Shaft	Ø 25.4	28.18	6.35
NO.03-Shaft	Ø 22.23	24.94	6.35

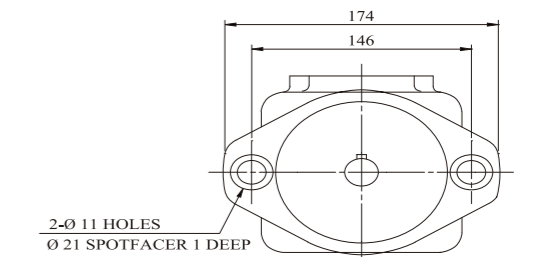

VQ Series Single Vane Pumps

Maximum pressure 210 bar

VQ25 (Flange-Mount Type)

Max. Pressure: 230 Kgf/cm² (Peak)
Max. Speed: 1800 rpm

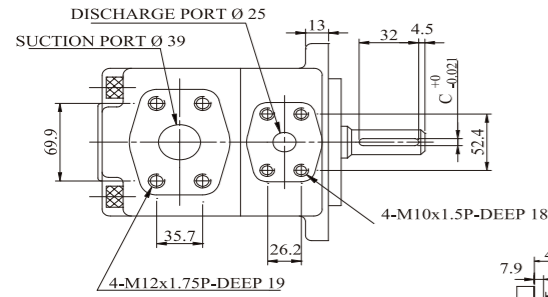

VQ25 (Base-Mount Type)

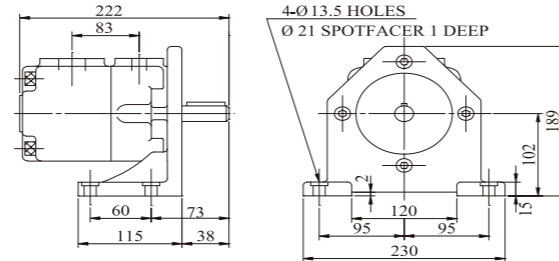

For other dimensions, please refer to the flange-mount type.

NO.04-Shaft
16/32 d.p. -13
teeth 30°
pressure angle
Flat root side fit.

	A	B	C	E
NO.01-Shaft	Ø 22.23	24.5	6.35	50.5
NO.02-Shaft	Ø 25.4	28.18	6.35	50.5
NO.03-Shaft	Ø 30	33	7	59
NO.04-Shaft	Spline shaft			

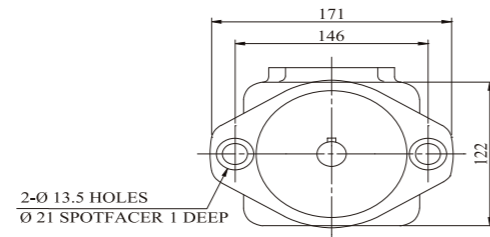
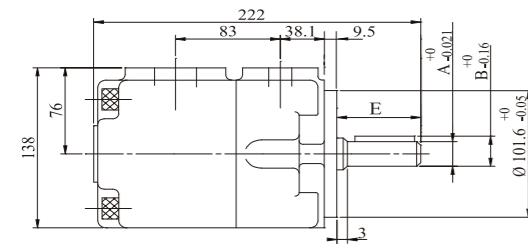

SVQ25 (Flange-Mount Type)

Max. Pressure: 230 Kgf/cm² (Peak)
Max. Speed: 1800 rpm

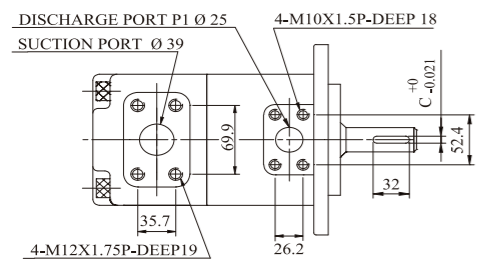

SVQ25 (Base-Mount Type)

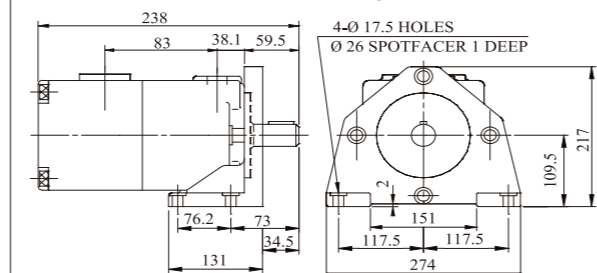

For other dimensions, please refer to the flange-mount type.

NO.04-Shaft
16/32 d.p. -13
teeth 30°
pressure angle
Flat root side fit.

	A	B	C	E
NO.01-Shaft	Ø 22.23	24.5	6.35	50.5
NO.02-Shaft	Ø 25.4	28.18	6.35	50.5
NO.03-Shaft	Ø 30	33	7	59
NO.04-Shaft	Spline shaft			

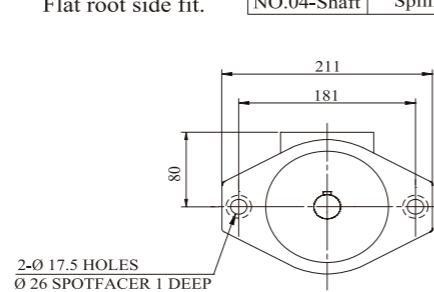
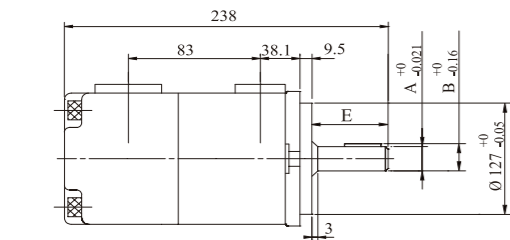

VQ Series Single Vane Pumps

Maximum pressure 210 bar

VQ35 (Flange-Mount Type)

Max. Pressure: 210 Kgf/cm² (Peak)
Max. Speed: 1800 rpm

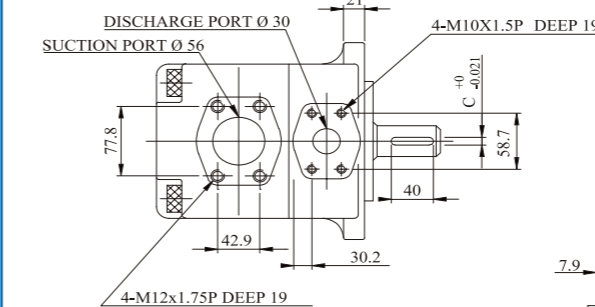

VQ35 (Base-Mount Type)

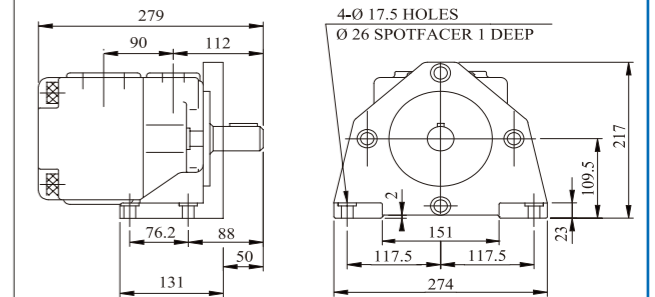

For other dimensions, please refer to the flange-mount type.

NO.03-Shaft
12/24 d.p.-14
teeth 30°
pressure angle
Flat root side fit.

	A	B	C
NO.01-Shaft	Ø 31.75	35.32	7.95
NO.02-Shaft	Ø 34.9	38.56	7.95
NO.03-Shaft	Spline shaft		

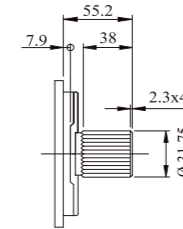
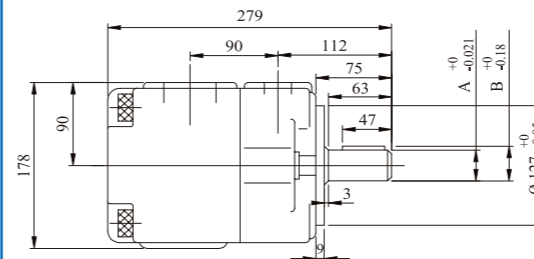

SVQ35 (Flange-Mount Type)

Max. Pressure: 210 Kgf/cm² (Peak)
Max. Speed: 1800 rpm

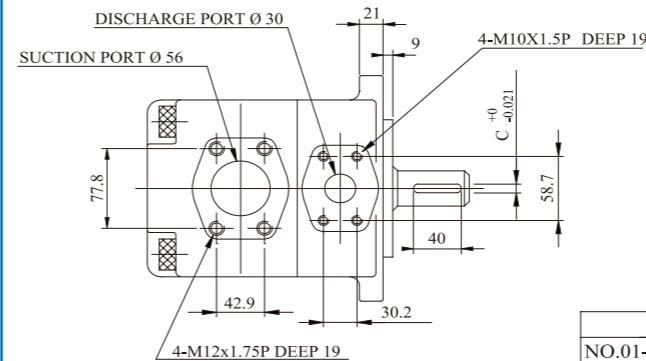

SVQ35 (Base-Mount Type)

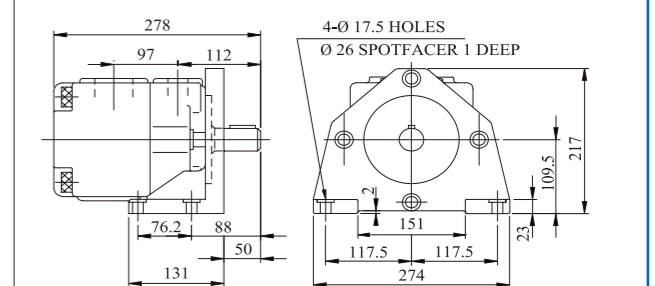

For other dimensions, please refer to the flange-mount type.

	A	B	C
NO.01-Shaft	Ø 31.75	35.32	7.95
NO.02-Shaft	Ø 34.9	38.56	7.95

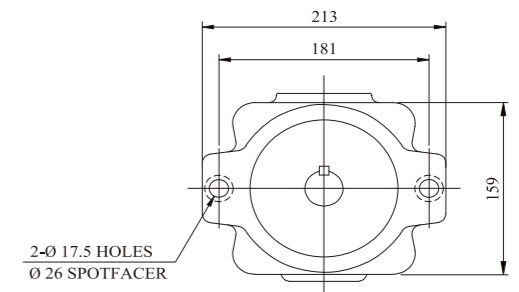
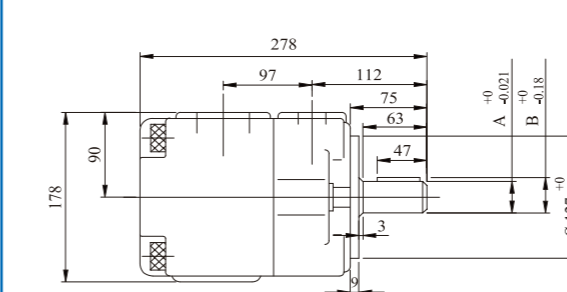

VQ Series Single Vane Pumps

Maximum pressure 175 bar

VQ45 (Flange-Mount Type)

Max. Pressure: 175 Kg/cm² (Peak)
Max. Speed: 1800 rpm

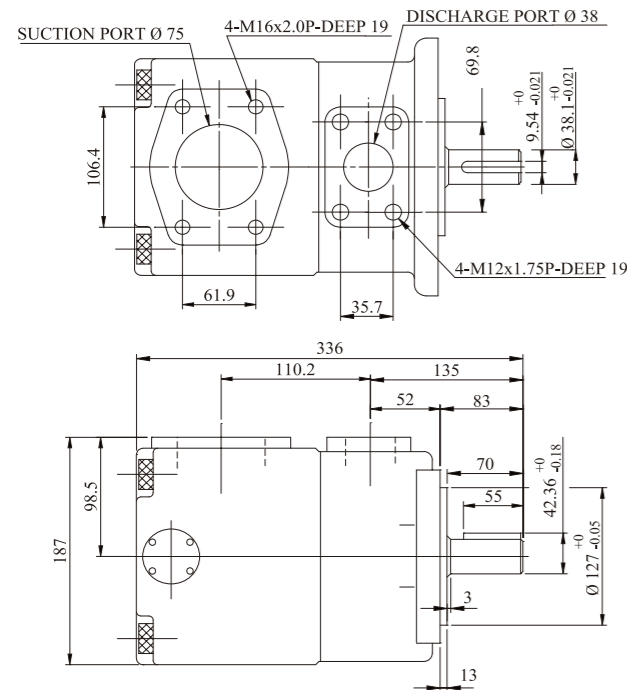

VQ45 (Base-Mount Type)

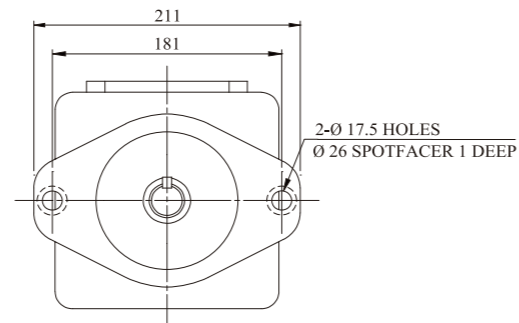
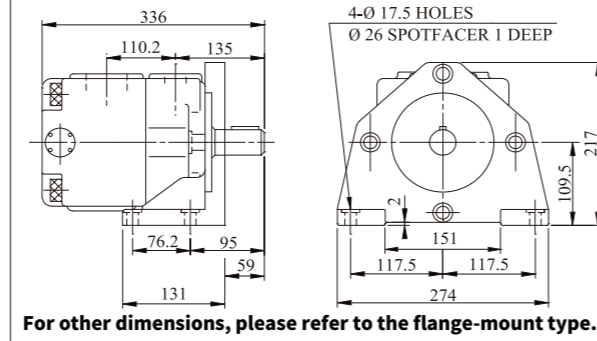

DVQ45 (Flange-Mount Type)

Max. Pressure: 175 Kg/cm² (Peak)
Max. Speed: 1800 rpm

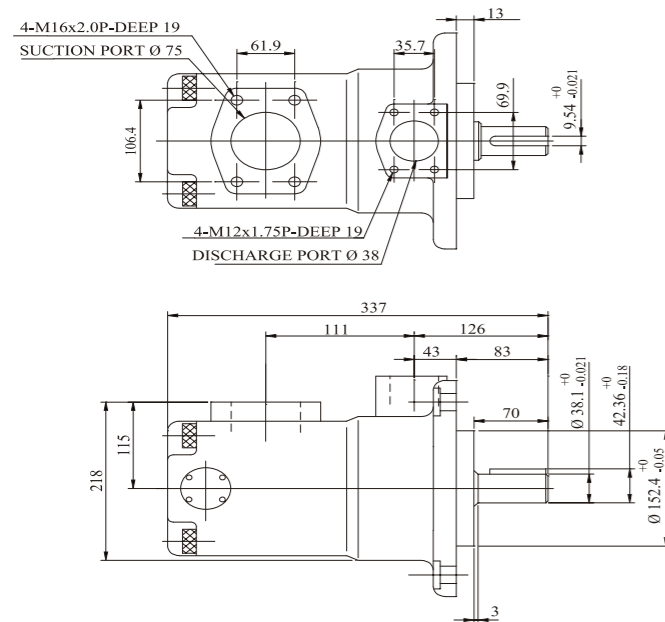

DVQ45 (Base-Mount Type)

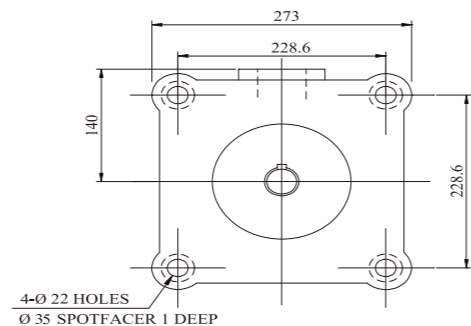
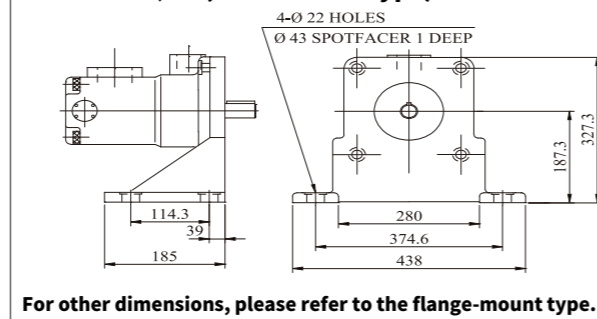

VQ Series Single Vane Pumps

Maximum pressure 175 bar

SVQ45 (Flange-Mount Type)

Max. Pressure: 175 Kg/cm² (Peak)
Max. Speed: 1800 rpm

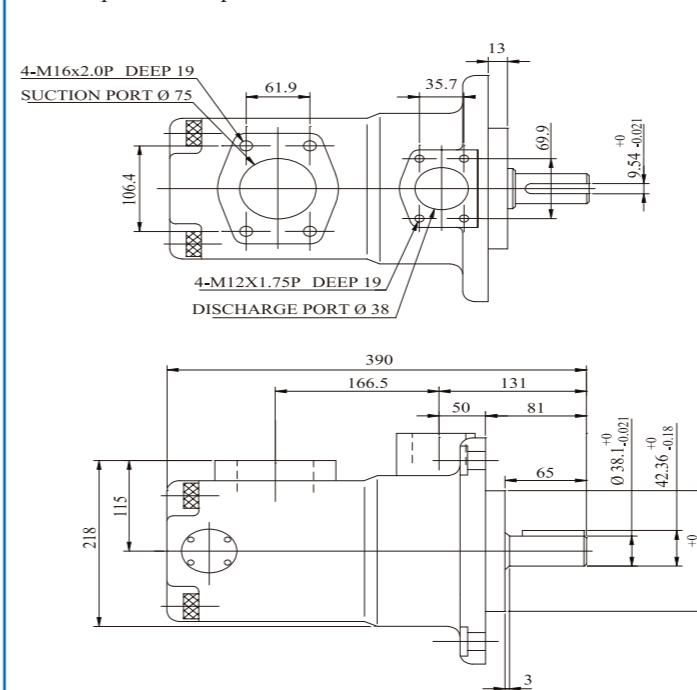

SVQ45 (Base-Mount Type)

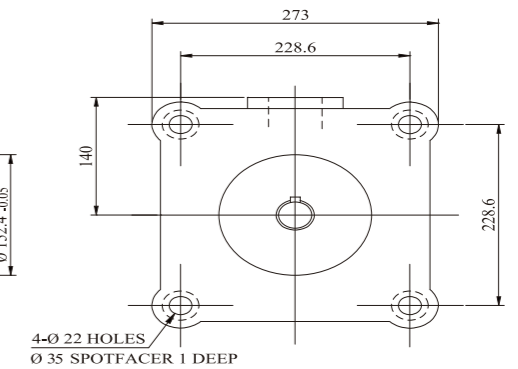
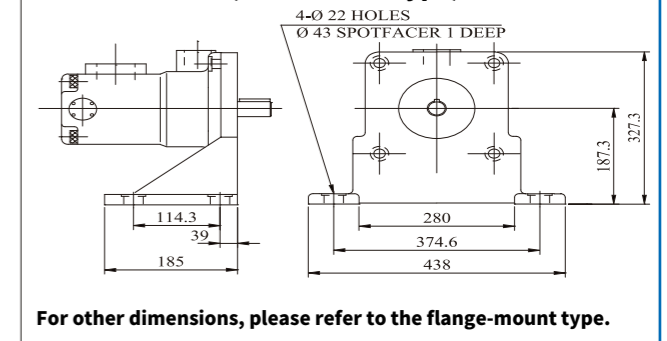

VQ Series Single Vane Pumps

Maximum pressure 210 bar

VQ Series Single Pump Exploded View

VQ15
VQ20
VQ25
VQ35
VQ45

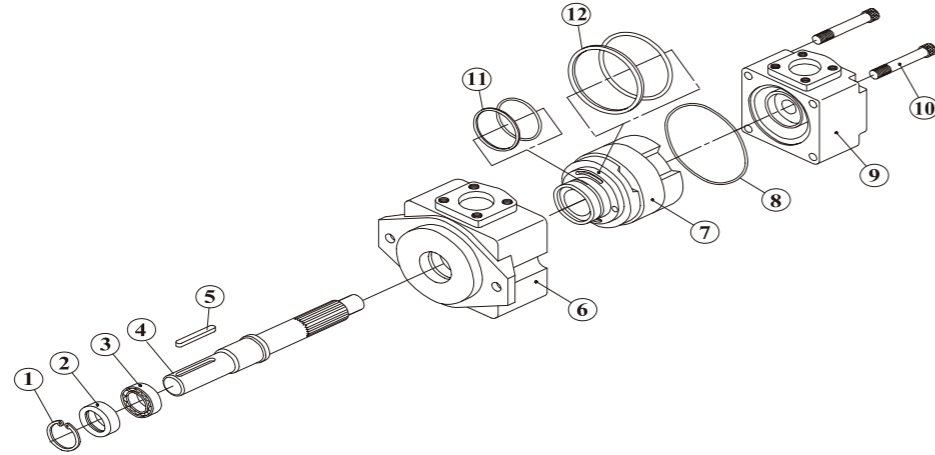

SVQ25
SVQ35
SVQ45
(DVQ45)

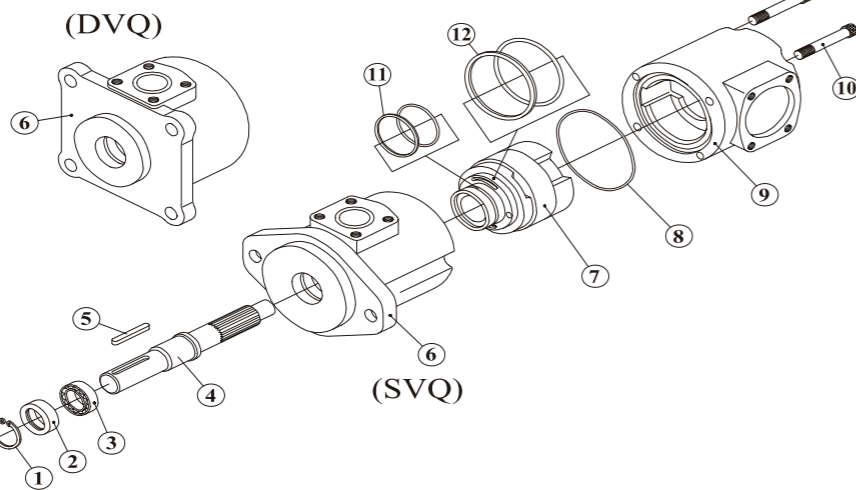

VQ Single Pump Parts List

- NO.1 Retainer Ring
- NO.2 Seal
- NO.3 Bearing
- NO.4 Shaft
- NO.5 Key
- NO.6 Housing
- NO.7 Cartridge Kit
- NO.8 O-Ring
- NO.9 Cover
- NO.10 Cap-Screw
- NO.11 O-ring & Endless Back-Up Ring
- NO.12 O-ring & Endless Back-Up Ring

VQ Series Double Vane Pumps

Maximum pressure 210 bar

VQ215 SVQ215
VQ225 SVQ315
VQ325 DVQ425
VQ425 SVQ425
VQ435 SVQ435
DVQ435

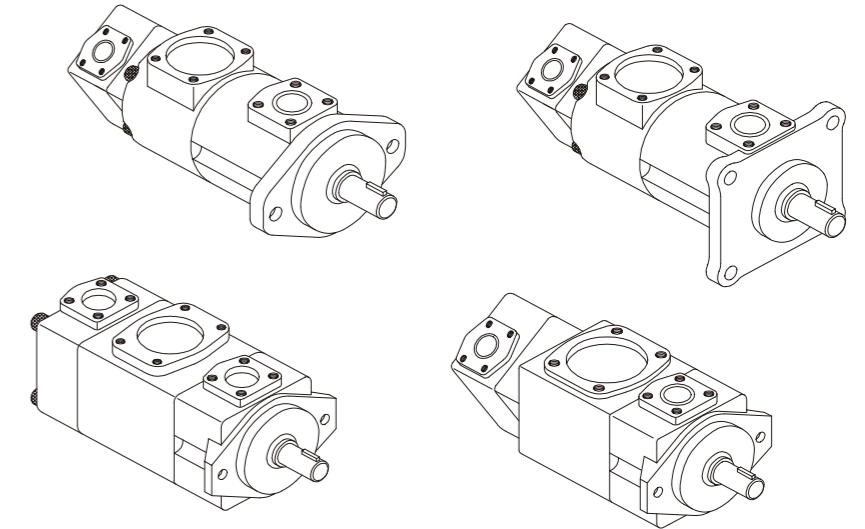

Dual Pump Ordering Guide

EX : (VQ215-26-17-F-RALD-02) EX : (SVQ315-94-17-F-RAAA-02)

Series Number	P1:Discharge Port c.c/rev Shaft End	P2:Discharge Port c.c/rev Cover End	Mounting Type	Shaft Rotation (view from Shaft End)	Discharge Port Position (P1) Shaft End Pump (view from Shaft End)	Suction Port Position (view from Shaft End)	Discharge Port Position (P2) Cover End Pump (view from Shaft End)	Shaft Type
VQ225	18,22,26,32 38,43,47,52 60,65,75	18,22,26,32 38,43,47,52 60,65,75	F: Flange Type	R: Clockwise	A:Upward (normal)	A:Upward (normal)	A:Upward (normal) B:Downward R:Right Hand L:Left Hand	-01 -02 -03
SVQ315	60,66,76 82,88,94 108,116,125	6,8,11,14 17,19,23 26,31,38						
VQ215 SVQ215	18,22,26,32 38,43,47,52, 60,65,75	6,8,11,14 17,19,23 26,31,38	L: Foot Type	L: Anti-Clockwise	B:Downward	B:Downward	A:On Right Hand Upward 45° (normal) B:On Right Hand Downward 45° C:On Left Hand Downward 45° D:On Left Hand Upward 45°	
VQ325	60,66,76 82,88,94 108,116,125	18,22,26,32 38,43,47,52, 60,65,75						
VQ425 SVQ425 DVQ425	136,156 189,200 216,237	18,22,26,32 38,43,47,52, 60,65,75						
VQ435 SVQ435 DVQ435	136,156 189,200 216,237	60,66,76,82, 88,94,108 116,125						

Dual-Pump Weight Chart (Kg)

	VQ215	VQ225	SVQ215	SVQ315	VQ325	VQ425	DVQ425	SVQ425	VQ435	DVQ435	SVQ435
Flange Type	24	30.6	32	44.4	50	63	73	80	76	84	91
Foot Type	29	35.5	40	52	58	71	104	111	93	115	122
Outlet & Inlet Flange	2.5	3.2	3.2	3.5	3.5	4.8	4.8	4.8	5.2	5.2	5.2

VQ Series Double Vane Pumps

Maximum pressure 210 bar

VQ215 (Flange-Mount Type)

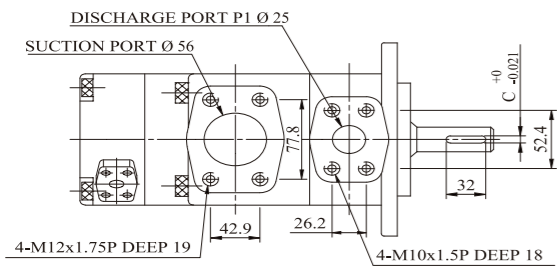

VQ215 (Base-Mount Type)

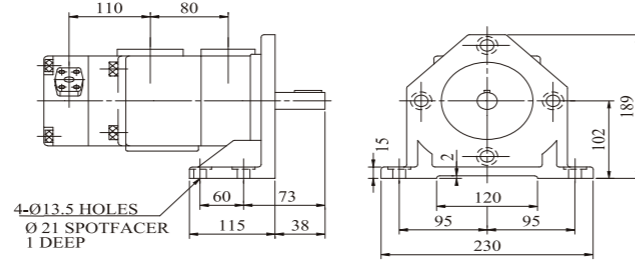

For other dimensions, please refer to the flange-mount type.

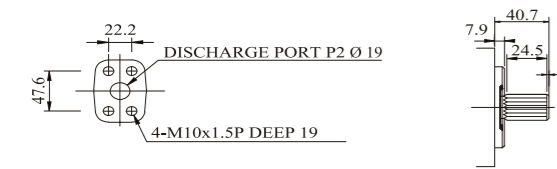

NO.04-Shaft
16/32 d.p. -13 teeth
30° pressure angle
Flat root side fit.

	A	B	C	L
NO.01-Shaft	Ø 22.23	24.5	6.35	61
NO.02-Shaft	Ø 25.4	28.18	6.35	61
NO.03-Shaft	Ø 30	33	7	68
NO.04-Shaft	Spline shaft 7/8" -13T			

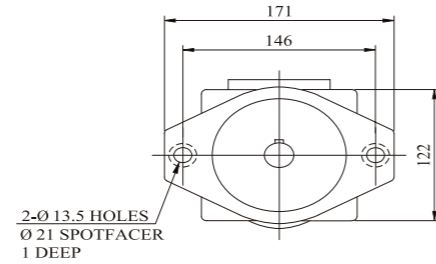
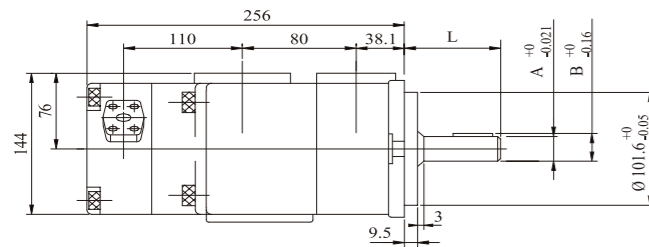

SVQ215 (Flange-Mount Type)

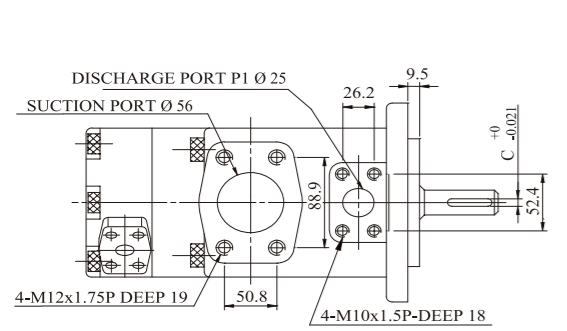

SVQ215 (Base-Mount Type)

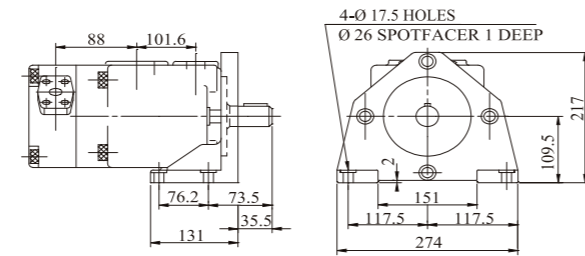

For other dimensions, please refer to the flange-mount type.

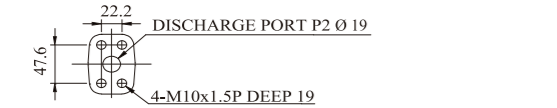

NO.04-Shaft
16/32 d.p. 13teeth
30° pressure angle
Flat root side fit.

	A	B	C	L
NO.01-Shaft	Ø 22.23	24.5	6.35	61
NO.02-Shaft	Ø 25.4	28.18	6.35	61
NO.03-Shaft	Ø 30	33	7	68
NO.04-Shaft	Spline shaft 7/8" -13T			

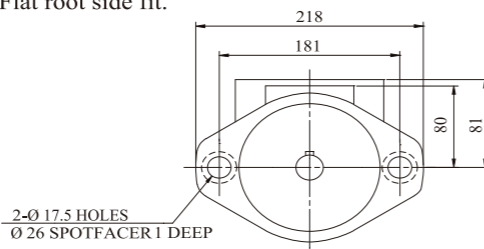
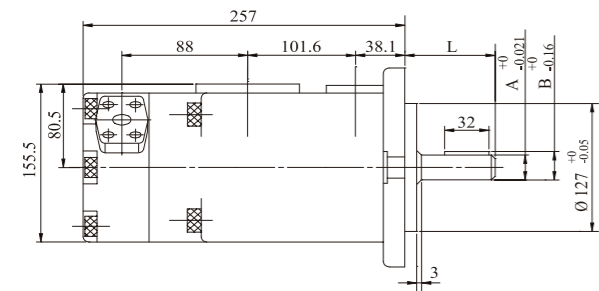

VQ Series Double Vane Pumps

Maximum pressure 210 bar

VQ225 (Flange-Mount Type)

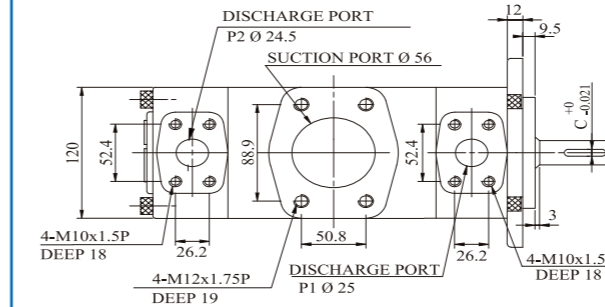

VQ225 (Base-Mount Type)

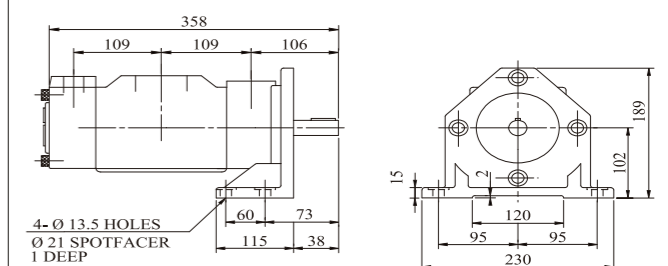

For other dimensions, please refer to the flange-mount type.

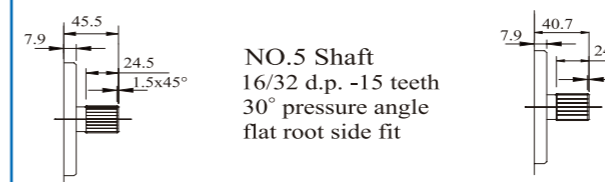

NO.5 Shaft
16/32 d.p. -15 teeth
30° pressure angle
flat root side fit

NO.04-Shaft
16/32 d.p. -13 teeth
30° pressure angle
flat root side fit.

	A	B	C
NO.01-Shaft	Ø 22.23	24.5	6.35
NO.02-Shaft	Ø 25.4	28.18	6.35
NO.03-Shaft	Ø 30	33	7
NO.04-Shaft	Spline shaft 7/8" -13T		
NO.05-Shaft	Spline shaft 1" -15T		

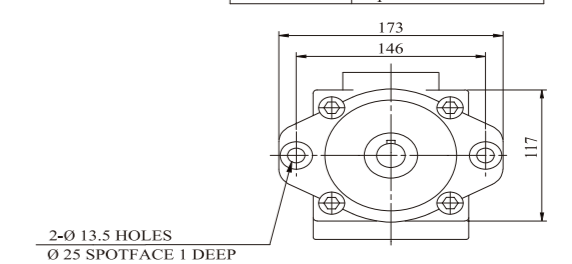
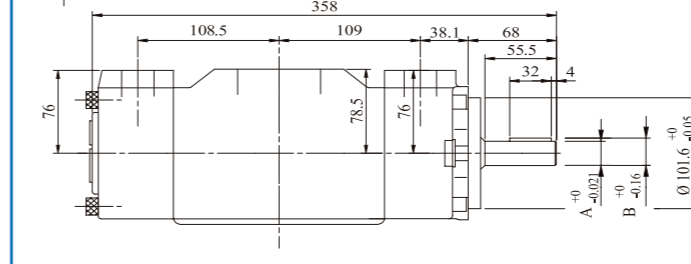

SVQ315 (Flange-Mount Type)

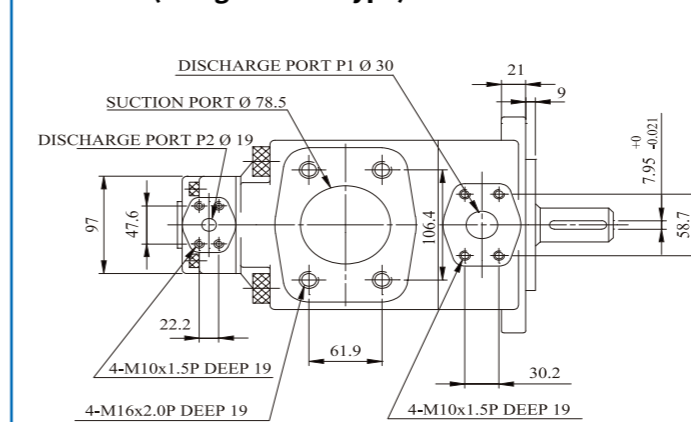

SVQ315 (Base-Mount Type)

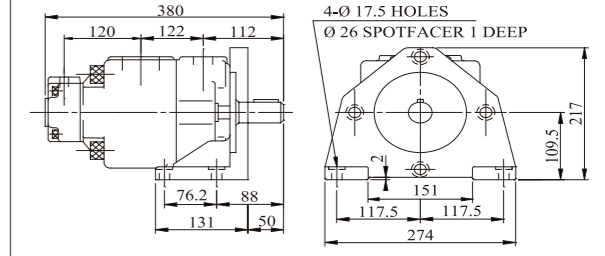

For other dimensions, please refer to the flange-mount type.

	A	B
NO.01-Shaft	Ø 31.75	35.32
NO.02-Shaft	Ø 34.9	38.56

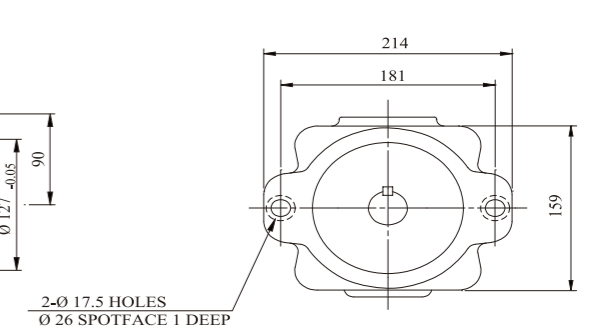
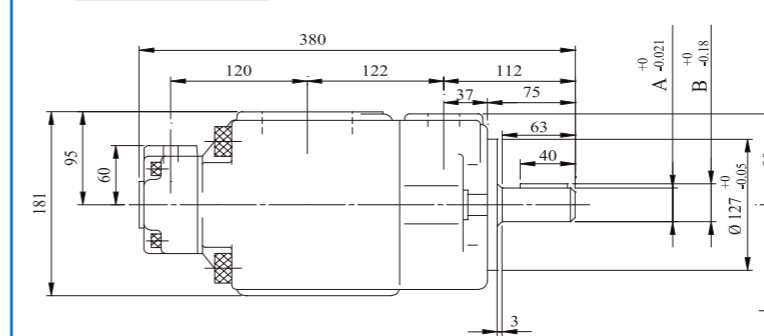

VQ Series Double Vane Pumps

Maximum pressure 210 bar

VQ325 (Flange-Mount Type)

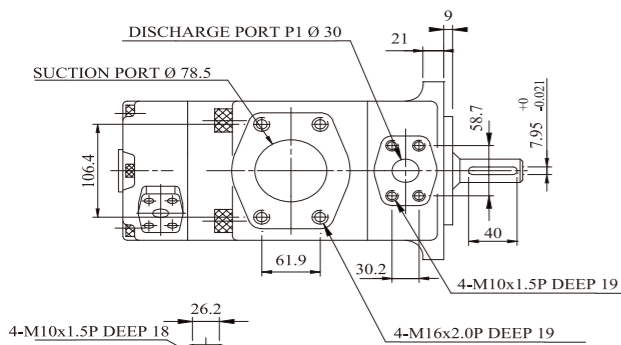

VQ325 (Base-Mount Type)

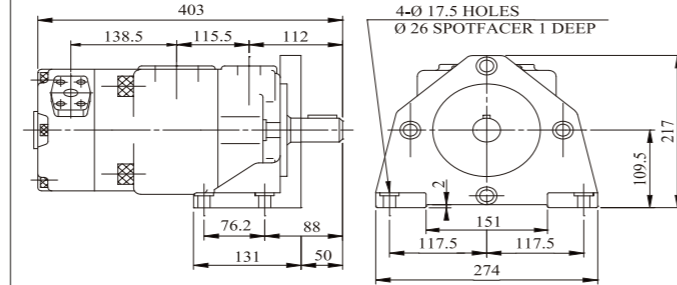

For other dimensions, please refer to the flange-mount type.

	A	B
NO.01-Shaft	Ø 31.75	35.32
NO.02-Shaft	Ø 34.9	38.56

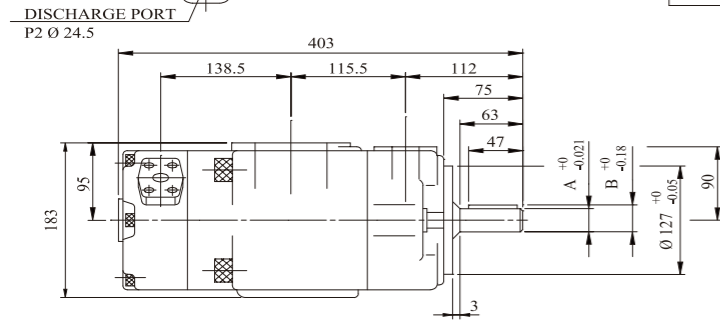

VQ425 (Flange-Mount Type)

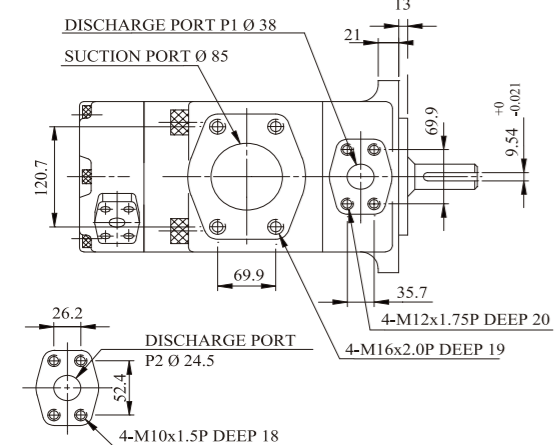

VQ425 (Base-Mount Type)

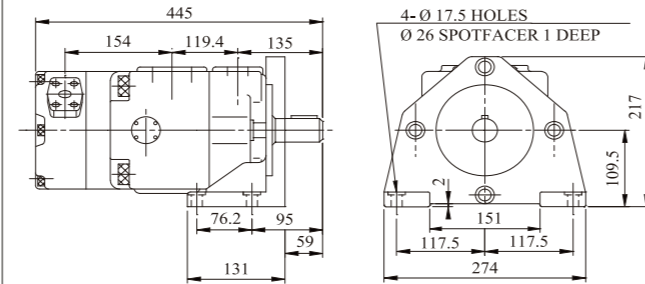

For other dimensions, please refer to the flange-mount type.

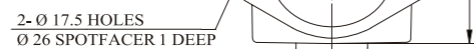
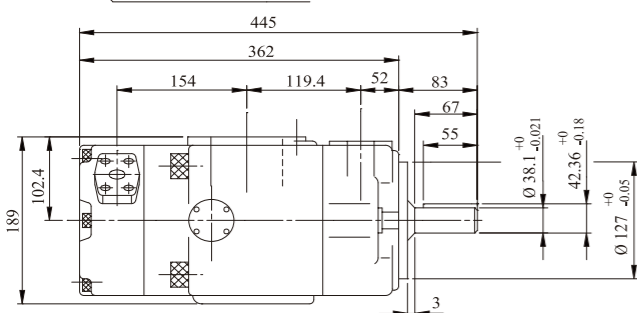

VQ Series Double Vane Pumps

Maximum pressure 210 bar

DVQ425 (Flange-Mount Type)

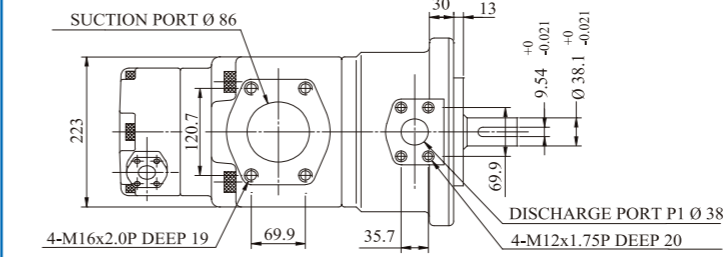

DVQ425 (Base-Mount Type)

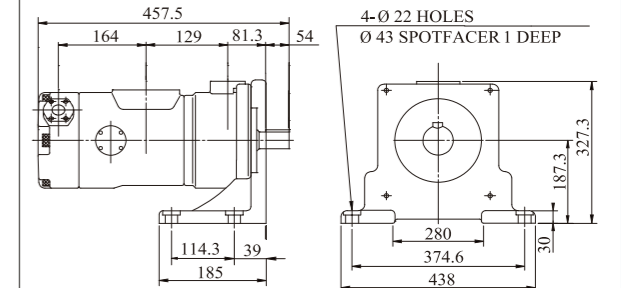

For other dimensions, please refer to the flange-mount type.

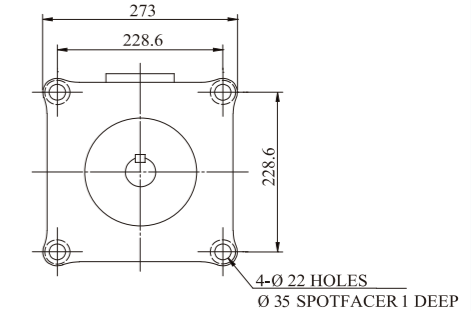
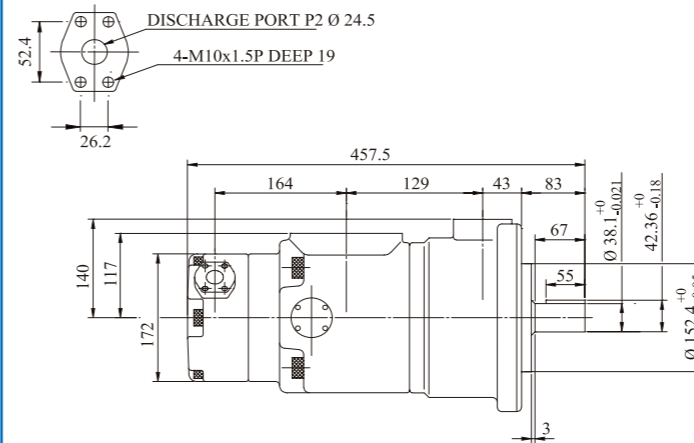

SVQ425 (Flange-Mount Type)

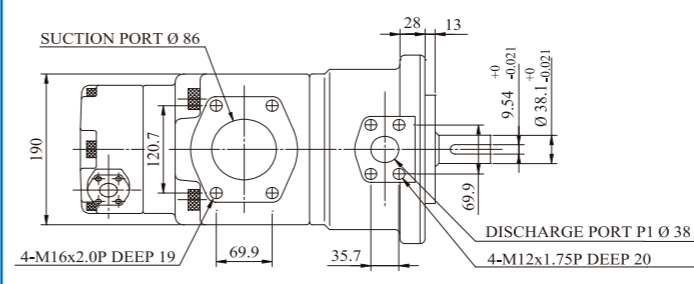

SVQ425 (Base-Mount Type)

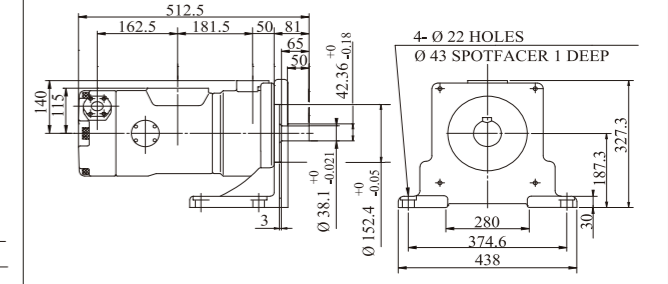

For other dimensions, please refer to the flange-mount type.

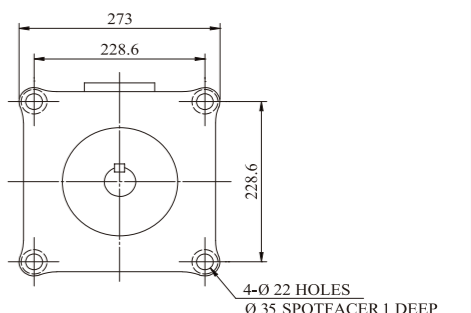
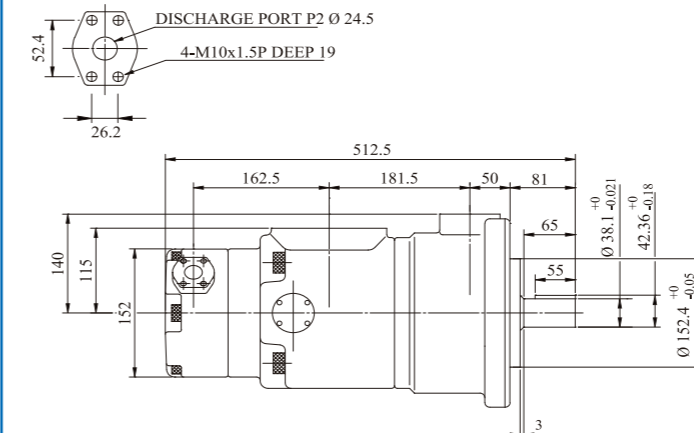

VQ Series Double Vane Pumps

Maximum pressure 210 bar

VQ435 (Flange-Mount Type)

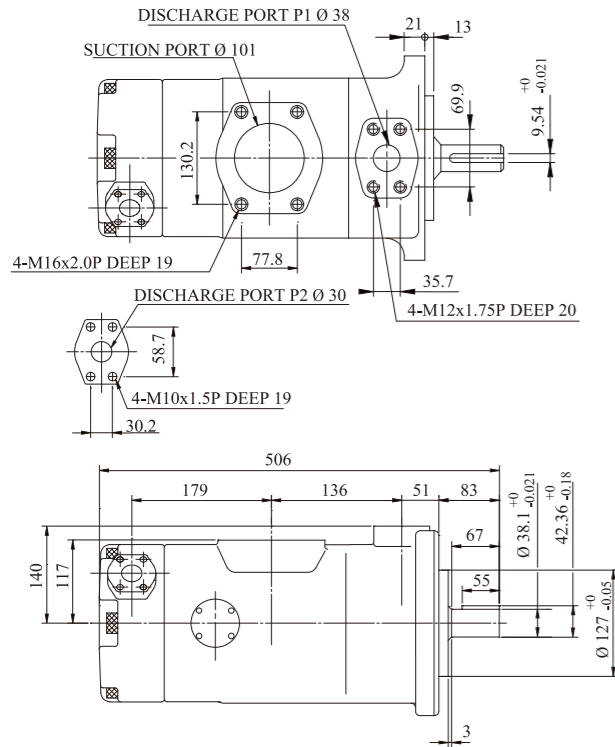

VQ435 (Base-Mount Type)

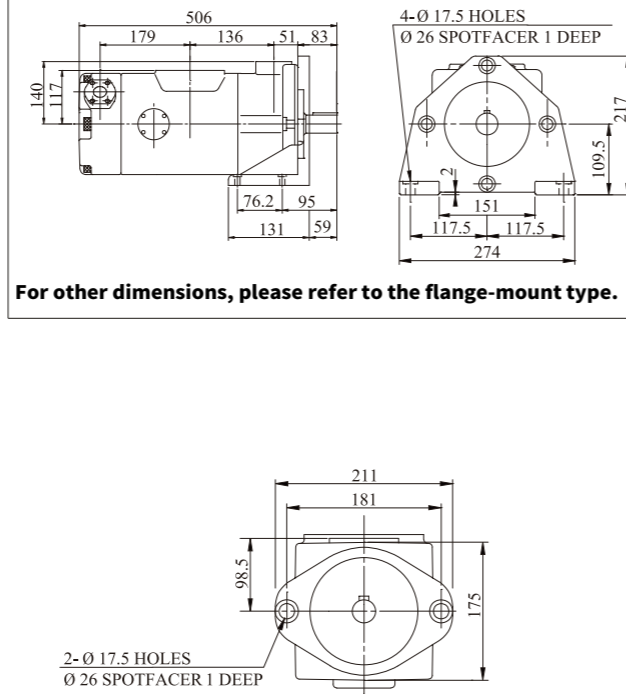

DVQ435 (Flange-Mount Type)

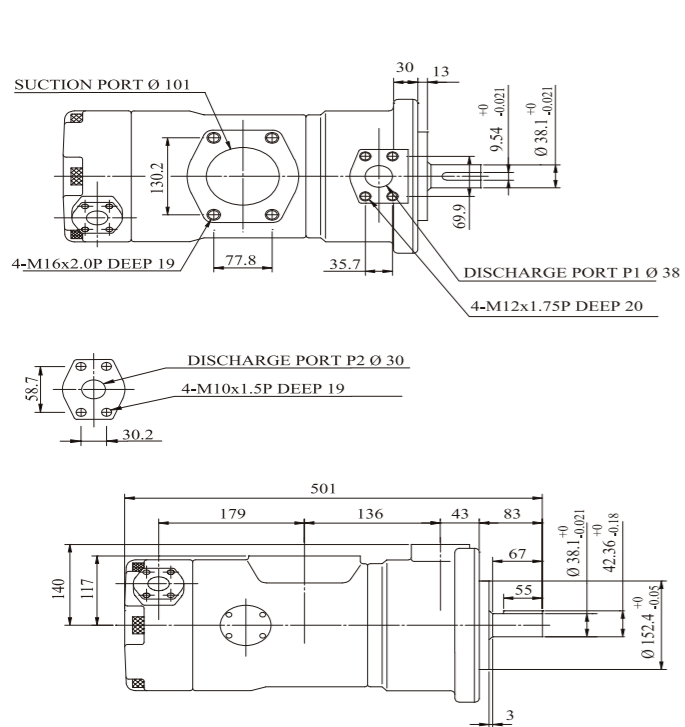

DVQ435 (Base-Mount Type)

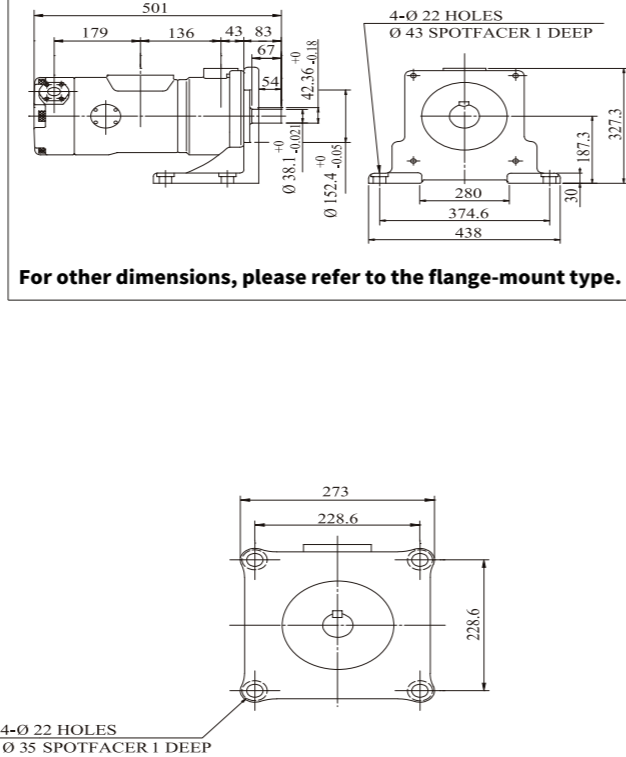

VQ Series Double Vane Pumps

Maximum pressure 210 bar

SVQ435 (Flange-Mount Type)

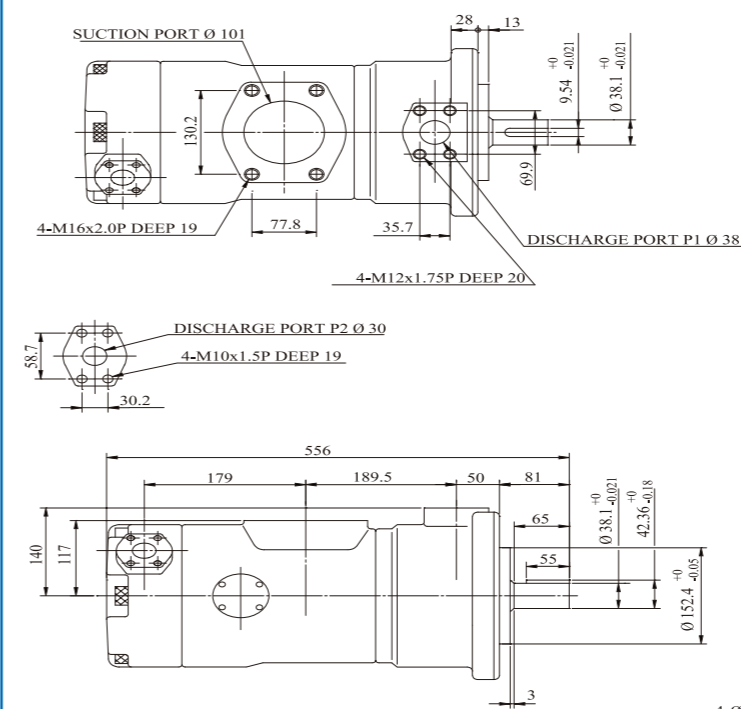

SVQ435 (Base-Mount Type)

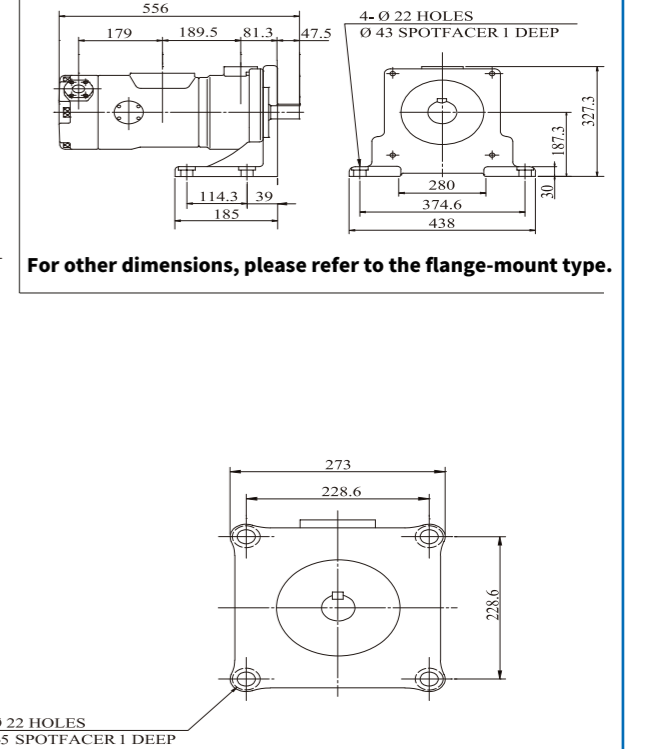

VQ Series Double Vane Pumps

Maximum pressure 210 bar

VQ Series Dual Pump Exploded View

VQ215
VQ225
VQ325
VQ425
VQ435

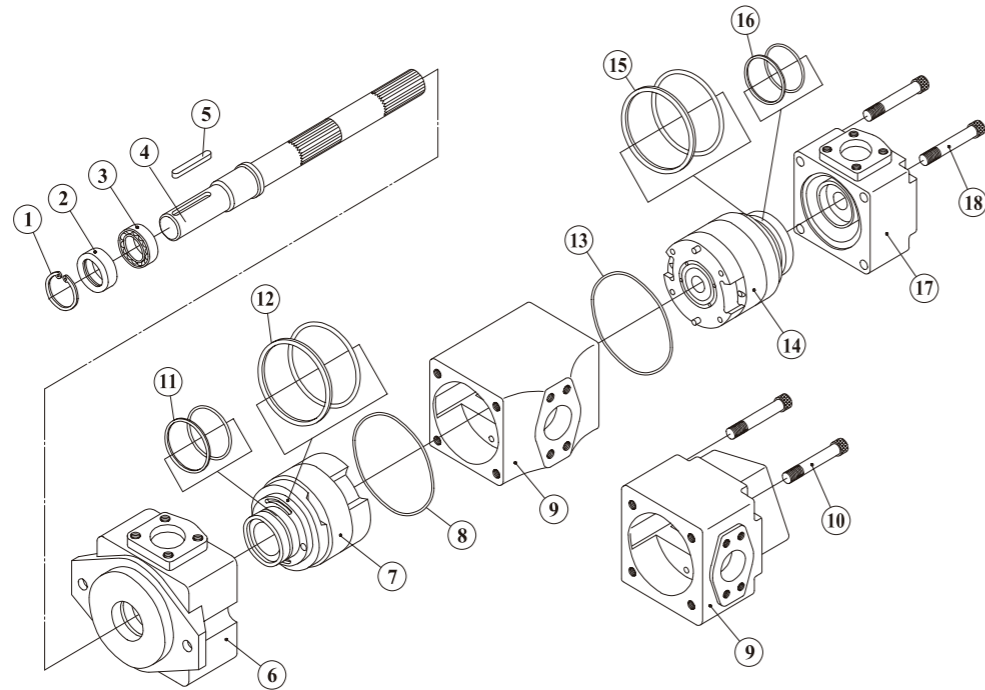

SVQ215
SVQ315
SVQ425
SVQ435
DVQ425
DVQ435

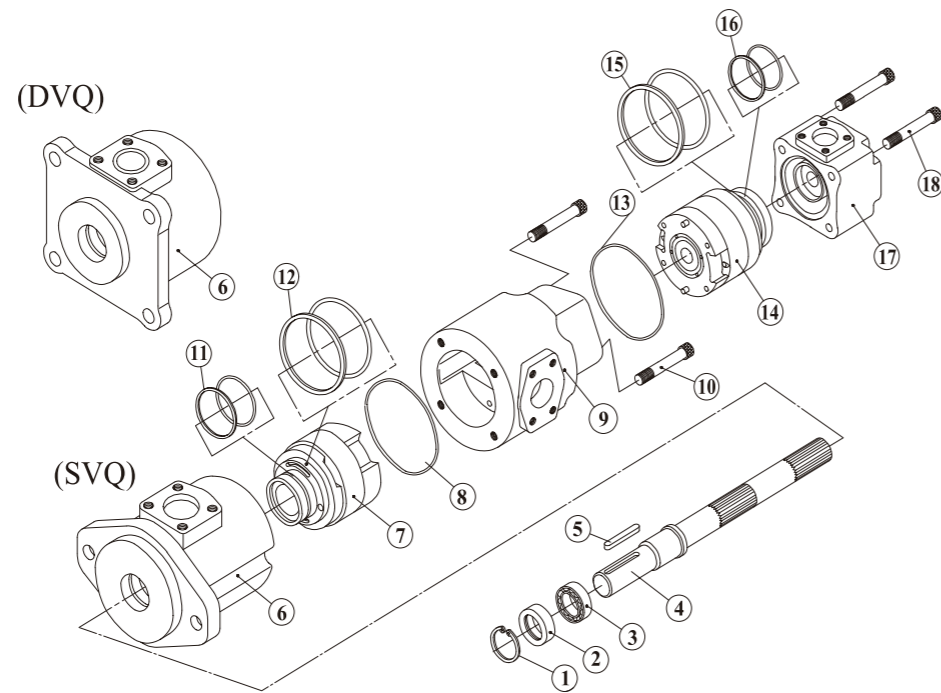

VQ Series Double Vane Pumps

Maximum pressure 210 bar

VQ Series Dual Pump Parts List

- | | |
|--------------------|-------------------------------------|
| NO.1 Retainer Ring | NO.11 O-ring & Endless Back-Up Ring |
| NO.2 Seal | NO.12 O-ring & Endless Back-Up Ring |
| NO.3 Bearing | NO.13 O-Ring |
| NO.4 Shaft | NO.14 Cartridge Kit |
| NO.5 Key | NO.15 O-ring & Endless Back-Up Ring |
| NO.6 Housing | NO.16 O-ring & Endless Back-Up Ring |
| NO.7 Cartridge Kit | NO.17 End cover |
| NO.8 O-Ring | NO.18 Screw |
| NO.9 Housing | |
| NO.10 Screw | |